

CAD FILE:

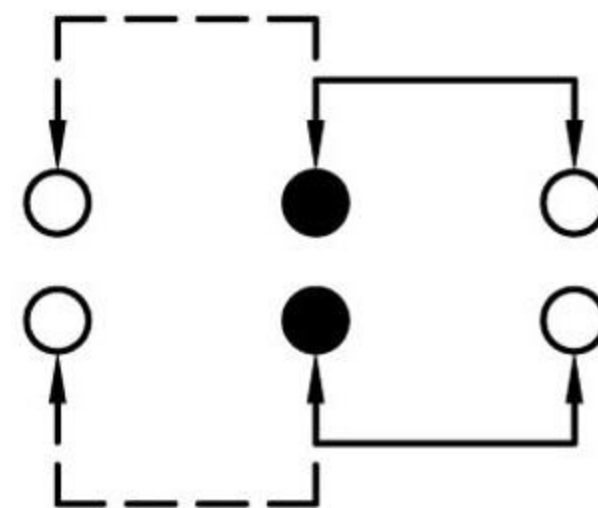

SCHEMATIC (NON-SHORTING)

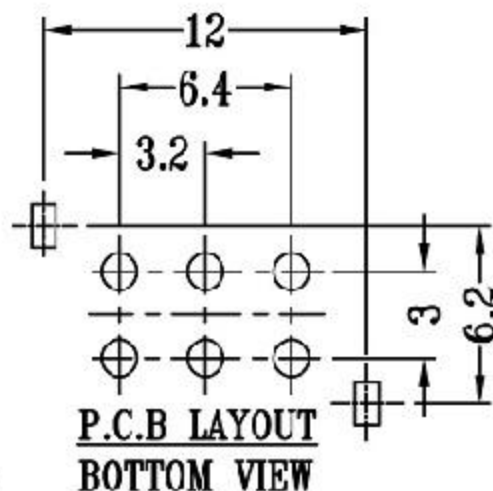
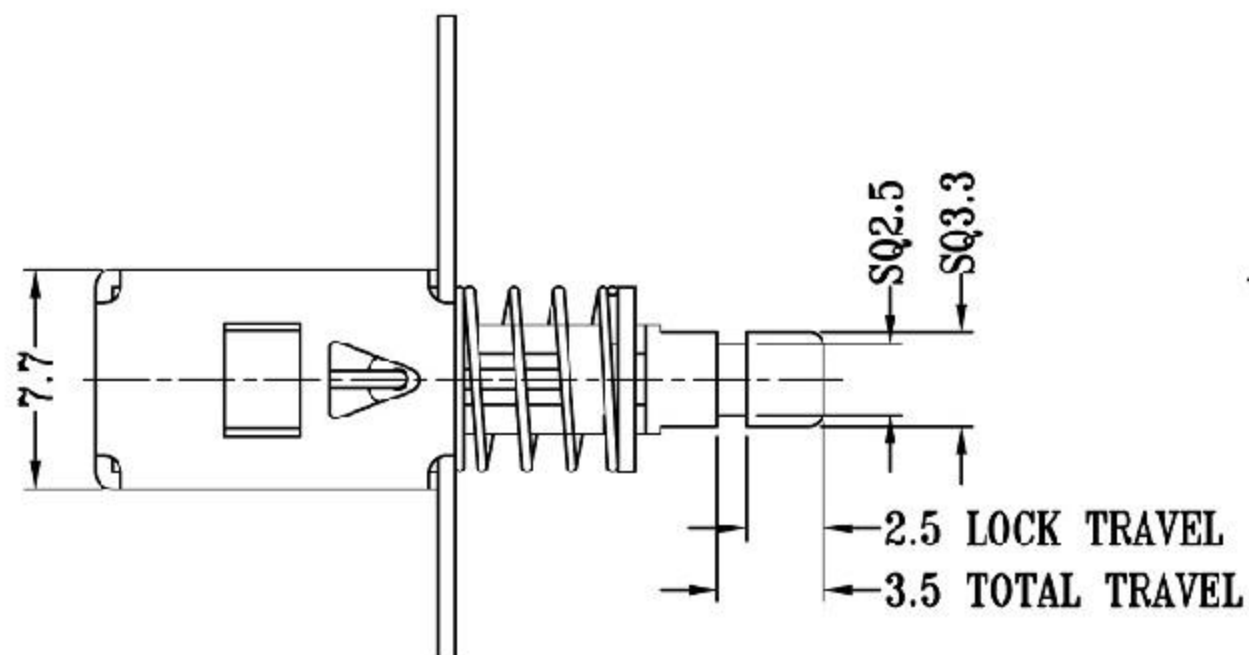
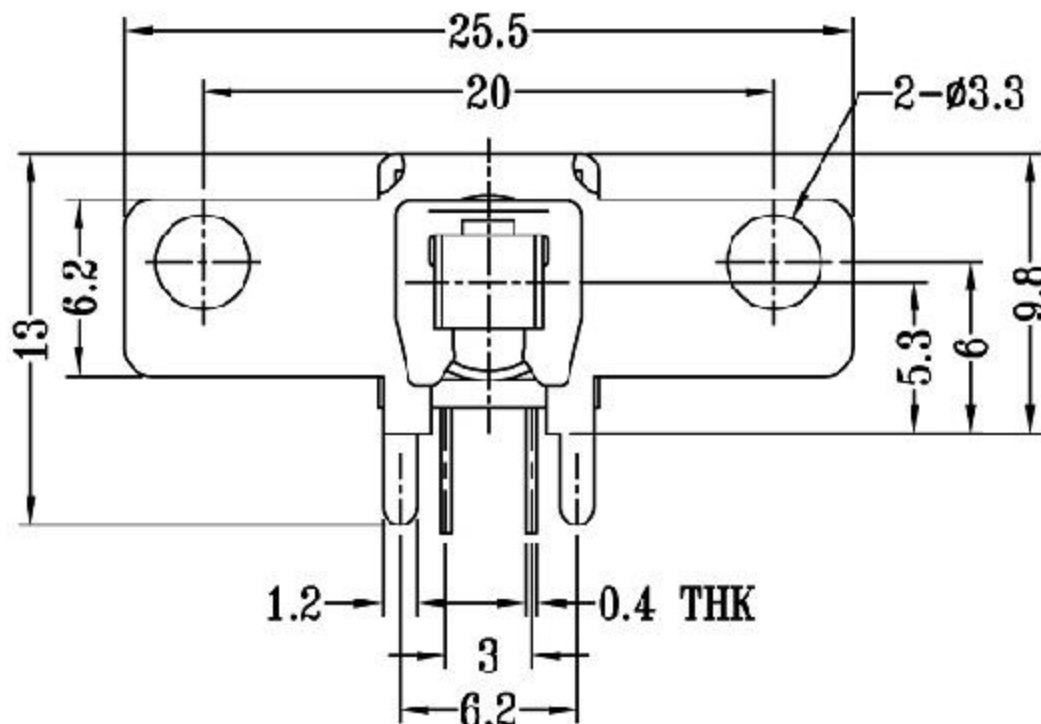
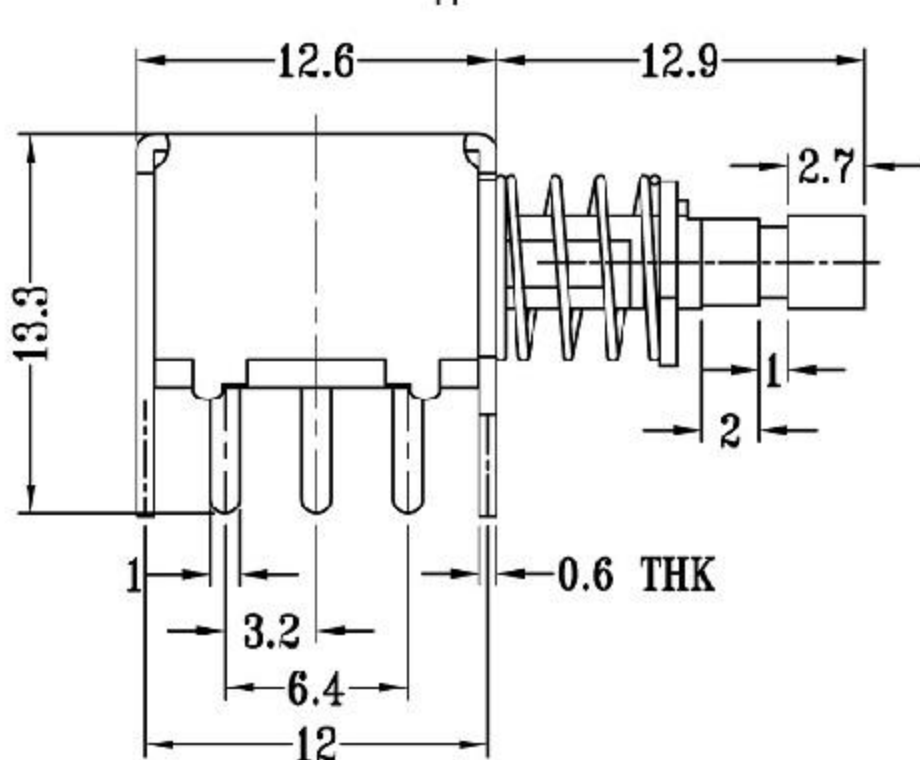

按键开关技术参数:

1. 额定负荷: DC 30V 50V 0.1A 0.5A
2. 接触阻抗: $\leq 50m\Omega$
3. 绝缘阻抗: DC 250V $\geq 100m\Omega$
4. 耐焊温度: $250 \pm 5^\circ$ 5s
5. 使用寿命: 100,000 cycles
6. 使用温度: -25°C to 80°C
7. 使用湿度: $\leq 85\%$ RH
8. 操作力: $240gf \pm 80gf$
9. 功能选择: 自锁/无锁
10. 按压力可定制

注: "*" 表示关键尺寸(6个).

NO.	PARTS	MATERIALS	Q'TY	FINISH	TOLERANCE UNLESS SPECIFIED	ISSUE	DATE	DESCRIPTIONS OF REVISION	APPD.
8									
7									
6	SPRING	STEEL WIRE	1	NATURAL	WITHIN 1.5mm : $\pm 0.1mm$	A	2012-11-06	初版	
5	CONTACT CLIP	PBS C5210R-EH	2	Ag CLAD	OVER 1.5mm : $\pm 0.2mm$	ISSUE	DATE		
4	BASE	PHENOLIC RESIN	1	NATURAL	TITLE : PUSH SWITCH			UNIT : mm	DRWG NO.:
3	TERMINAL	BRASS STRIP	6	Ag PLATED OVER Ni PLATED	MODEL:			SCALE: 2:1	
2	FRAME	Electrolytic strip	1	NATURAL	东莞市高迪电子有限公司			DWN.	2012-11-06
1	KNOB	PC	1	BLACK				CHK'D	2012-11-06
								APPD.	2012-11-06